

Aeroshield II Installation Instructions

#B91977

For Aeroshield 76072***

Peterbilt 384 and 386

***Color codes; 001=Clear, 002=Smoke

1. Attach end cap to Aeroshield by sliding splice plate into aluminum extrusion. Secure with a #8-32x1/4" machine screw. Place end cap over splice plate and attach with a #8-32x1/4" machine screw, as shown in illustration. Repeat procedure for other side.
2. Cover the top portion of hood behind grab handle with masking tape for temporary protection.
3. Place shield so that the front edge of the extrusion is 4" back from the edge of the grill crown, and is parallel with the back edge of the grille crown. Slide the shield forward or backward until the end caps wrap flush to the hood.
4. Holding shield in place with extrusion flat against hood, draw a line onto the masking tape along front edge of extrusion as shown in illustration.
5. To locate the mounting holes, measure from the center of the hood 3 1/2" and 16" toward the outer edges of the hood as shown in the illustration. At each distance, measure back 1-1/8" from the line drawn on the masking tape, and mark mount hole location.
6. Drill 5/16" diameter holes at marked. Remove masking tape.
NOTE: When drilling holes through hood, make sure area below is clear.
7. Slide the carriage bolts into the slotted extrusion so that the carriage bolts align with the holes, Fasten shield in place using the flat washers, lock washers, and hex nuts as shown in the illustration. INSPECT UNDER HOOD FOR CLEARANCE.
8. Press endcap against hood firmly. Mark hole location and drill a 9/32" diameter hole. Fasten end cap using a pan phillips head screw, flat washer, lockwasher, and hex nut as shown in the illustration. Repeat procedure for other side.
9. Align plastic wing of shield with endcap. Using the existing hole in endcap as a template, drill a 3/16" diameter hole through the plastic wing and fasten with small screw and nut as shown in illustration. Repeat procedure for other side.

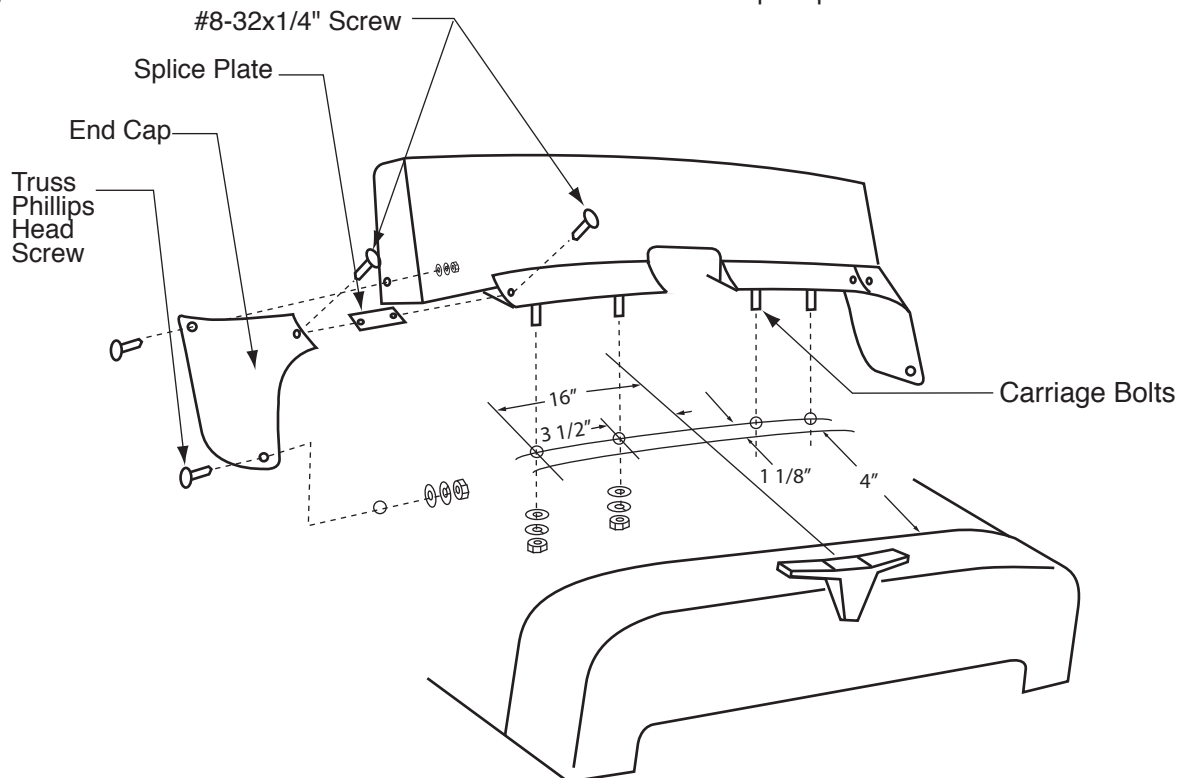

Cleaning: Do not use solvents of any kind. Never wipe shield when dry. Use plenty of soap and water. Use a clear non-cleaning wax to remove light scratches in shield.

Belmor offers other fine products including:
Winterfronts - Bugscreens - Sunvisors - Rock Guards
Ask your dealer for specific applications