

Installation Instructions

I - Sheet Number BELASK03 Rev.B

BELMOR

BECAUSE YOU DRIVE **HEAVY DUTY.**

Aeroskin II™

**For proper installation and best possible fit, please read all instructions BEFORE you begin.
For technical assistance or to obtain missing parts, please call Customer Relations at 1-800-241-7219.**

Important Safety Information



- CAUTION - Before driving, ensure that the Aeroskin II is properly secured to vehicle.
- Do not use automatic "brush-style" car washes.
- Do not use cleaning solvents of any kind.
- Periodically check all components for tightness.

Contents

NOTE: Actual product may vary from illustration.

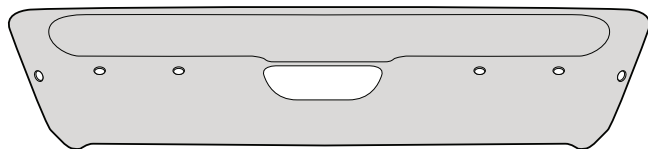

Aeroskin II



Well Nut
x6

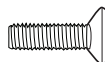

Bolt
x6



Washer
x6



Surface
Prep
x2



Wrench
x1



Alcohol
Pad
x6

Tools Required



Car Wash Supplies



Clean Towel

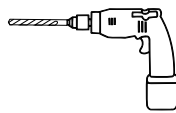

Drill with
1/2" Bit



Grease pencil

Installation Steps

NOTE: Actual application may vary slightly from illustrations.



Prior to installation, wash the hood of vehicle and dry with a clean cloth.

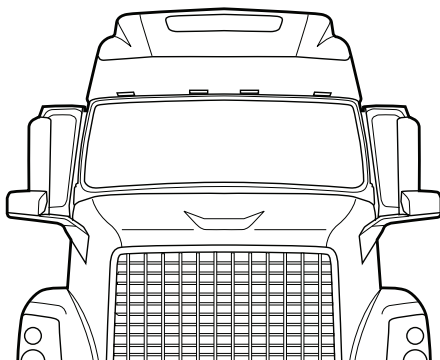

Use the alcohol pads to clean the entire LEADING EDGE of the hood.

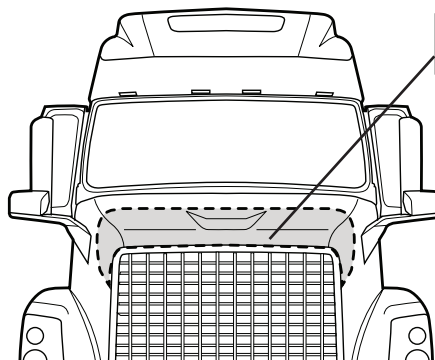

Installation Steps

NOTE: Actual application may vary slightly from illustrations.

Expose 2" (5 cm) of tape liner from each section of Aeroskin. Ensure you can access the free ends of tape liner.

NOTE: Inspect part thoroughly to confirm all sections of tape liner are exposed.

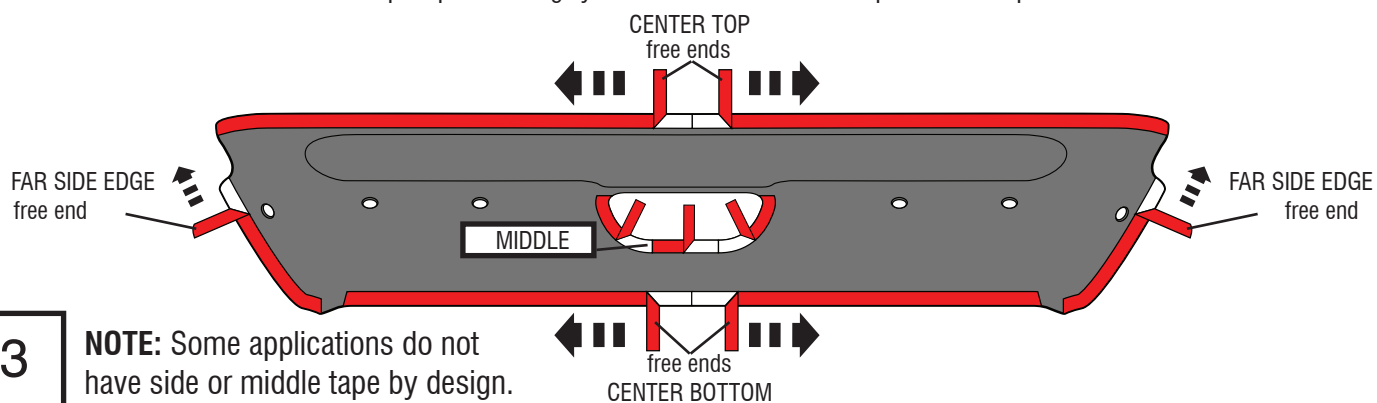

3

NOTE: Some applications do not have side or middle tape by design.

Center the Aeroskin on the hood. Lightly press on exposed areas of tape to temporarily affix part in position.

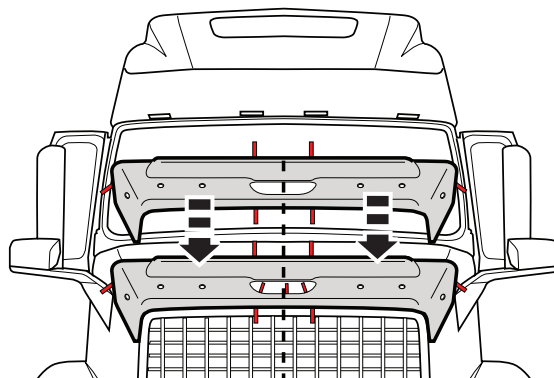

4

Use a grease pencil to mark the location of (6) holes and lightly trace along top and side edges of the hood surface.

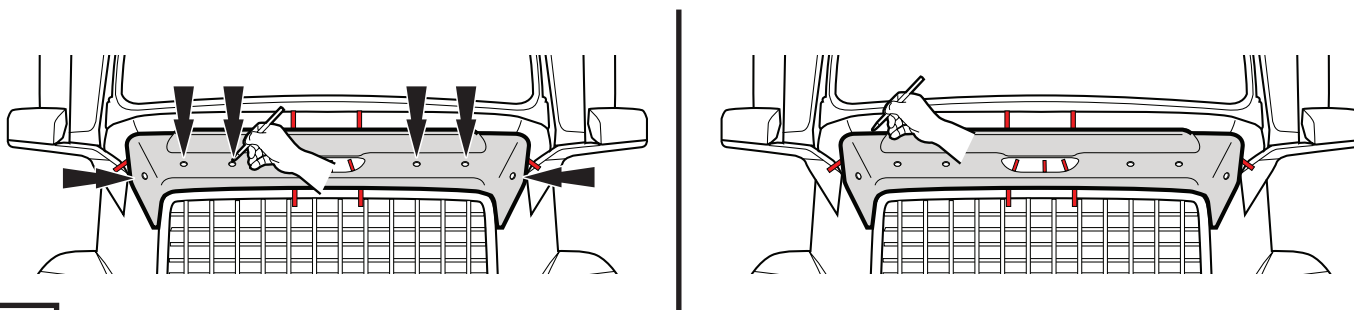

5

Remove Aeroskin and set aside.

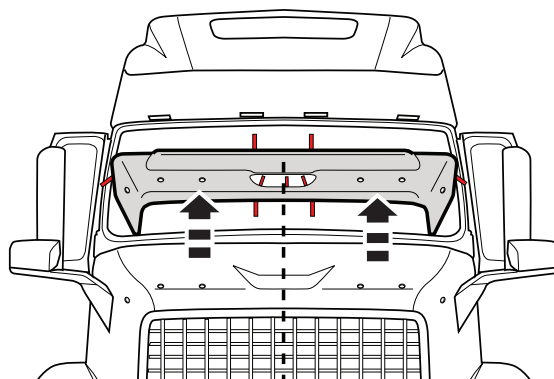

6

Installation Steps

NOTE: Actual application may vary slightly from illustrations.



Using a drill and a 1/2" drill bit, drill holes in locations marked in **Step 6**. Insert (6) well nuts in holes

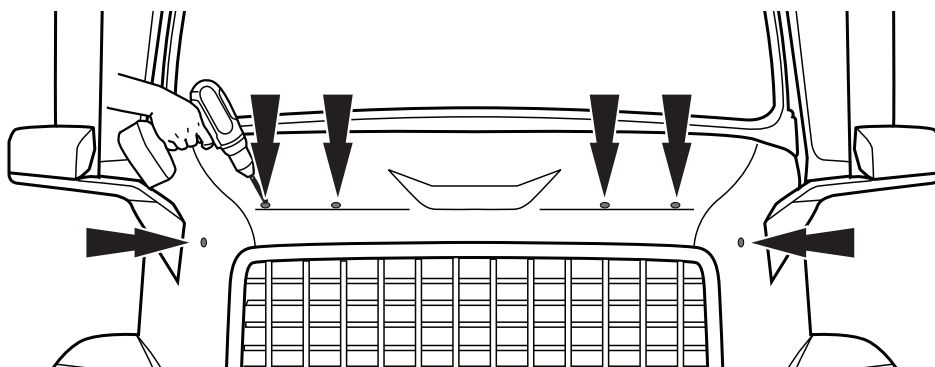

7



Apply adhesive promoter to truck hood inside previously traced area where tape will adhere.

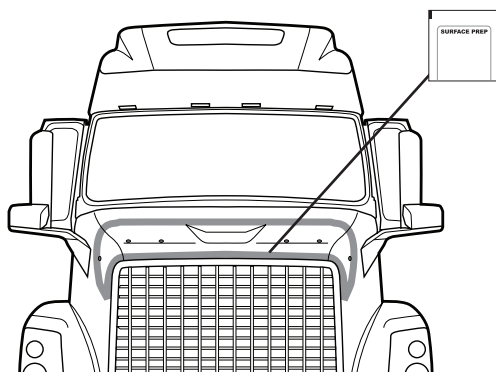

8



Place the hood shield on the hood and loosely install a bolt and washer through the hood shield and into the well nut in (6) locations. Be sure tape liner ends are exposed.

DO NOT TIGHTEN.

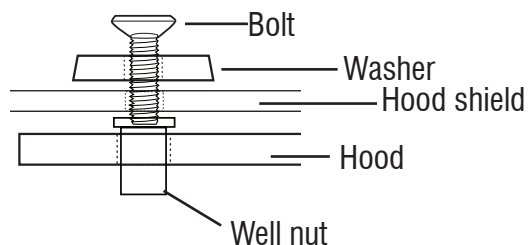
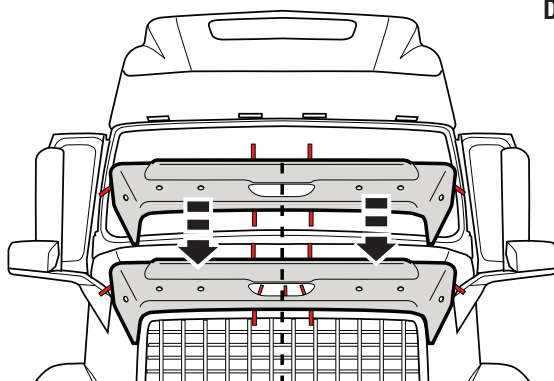

9

Begin removing remaining tape liner, beginning with the drivers side CENTER TOP. Grasping the free end, pull tape gently in 6" (15 cm) sections, while applying even pressure with hand to Aeroskin. Repeat process for passenger side.

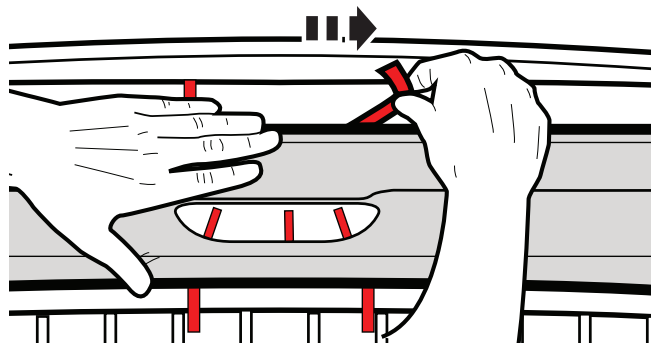

CAUTION: You must apply even pressure **from center section out** to each end of part, in order for proper adhesion to hood.

10

NOTE: Do not apply pressure closer than 6" (15 cm) to tape liner as it could accidentally break.

Installation Steps **NOTE:** Actual application may vary slightly from illustrations.

Using the same process, remove tape liner from the driver side CENTER BOTTOM of hood skin. Repeat for passenger side.

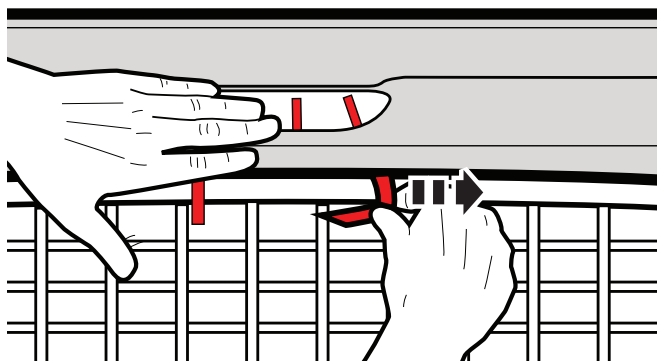

CAUTION: You must apply even pressure **from center section out** to each end of part, in order for proper adhesion to hood.

11

Again using the same process, remove tape liner from the driver side FAR SIDE EDGE of Aeroskin. Repeat for passenger side.

NOTE: If middle section has tape also, remove it at this time.

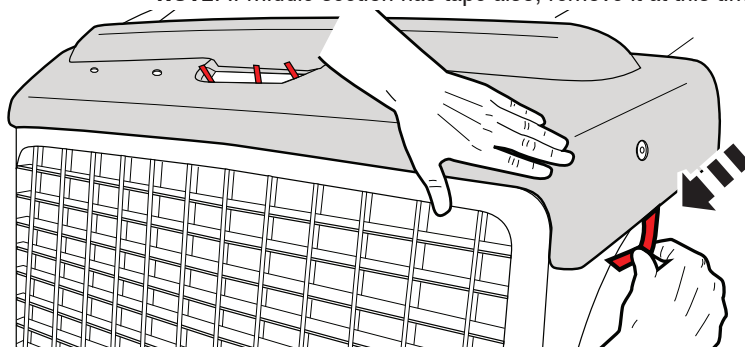

NOTE: Some applications do not have side or middle tape by design.

12

Press firmly along all edges of Aeroskin to ensure adhesion of tape to hood surface. Tighten (6) screws with wrench.

DO NOT OVERTIGHTEN.

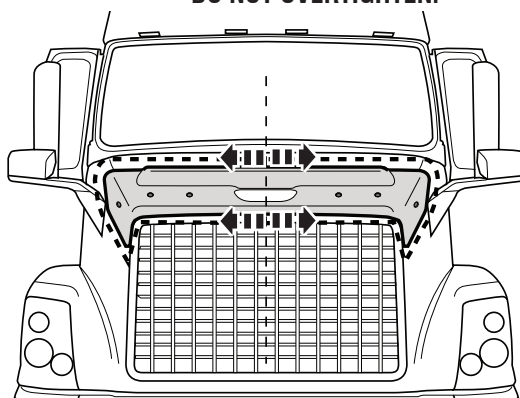

13

Care and Cleaning

- Wash only with mild soap & dry with a clean cloth.

Congratulations!

You have purchased one of the many quality Belmor[®] branded products offered by Lund International, Inc. We take the utmost pride in our products and want you to enjoy years of satisfaction from your investment. We have made every effort to ensure that your product is top quality in terms of fit, durability, finish and ease of installation.

BELMOR
BECAUSE YOU DRIVE **HEAVY DUTY.**

Lund International

800-241-7219 • Visit us at lundinternational.com

© 2017 Lund International, Inc. All rights reserved.

Auto Ventshade[™], the Auto Ventshade[™] logo and the AVS[™] logo are trademarks of Lund International, Inc.

